



# MPI-32 User's Guide & Installation Manual



August, 2004

## TABLE OF CONTENTS

Section	Page
1. System Description	3
2. Installation	4
3. Programming	12
4. Start-up Procedures	14
5. Troubleshooting	15
6. General Specifications	18

## 1. System Description

The MPI-32 is a high-output capacitive-discharge, crankshaft referenced, ignition system and is intended to be used on engines that employ two coils per cylinder. The coils can be fired simultaneously or independently. The system uses a single display module that allows the user to view all 32 spark plug voltages and related diagnostic messages. The system uses two MPI-16 boards (Controller A and Controller B) that are integrated into a single system. The MPI-32 has a higher primary voltage output (300V) than the MPI-16/8 products. This higher energy requirement addresses the higher demand for ignition power in large bore cylinders. Additionally, the hardware and firmware integration of these boards makes it different than simply having two separate MPI-16's. Refer to figure 1.0 MPI-32 Block Diagram.

There are two separate connectors for two primary harnesses; each is complete with its own sense lead and U lead. There is no need for switching the sense lead between sets of coils since each set has a dedicated sense lead.

The system inputs are internally paralleled so that there is no need for duplicate sensors. For powered sensors (Hall-Effect types) controller A provides the sensor power. An off board, din rail style terminal strip is provided for field wiring. The wiring details for each interface will be discussed in detail in the installation section.

The controller and the panel programs have been integrated to provide automatic parallel operation of several key parameters. For example, the tank voltage, timing adjust, auto delay, auto/man modes, 1/Rev position parameters are accessed on controller A and are automatically used by controller B without operator intervention.

For programming convenience the user need only to program controller A and with one key press the system will copy all parameters into controller B. Then a single key press performs a "save" operation on both controller A & B automatically.

### ● MPI-32 Block Diagram

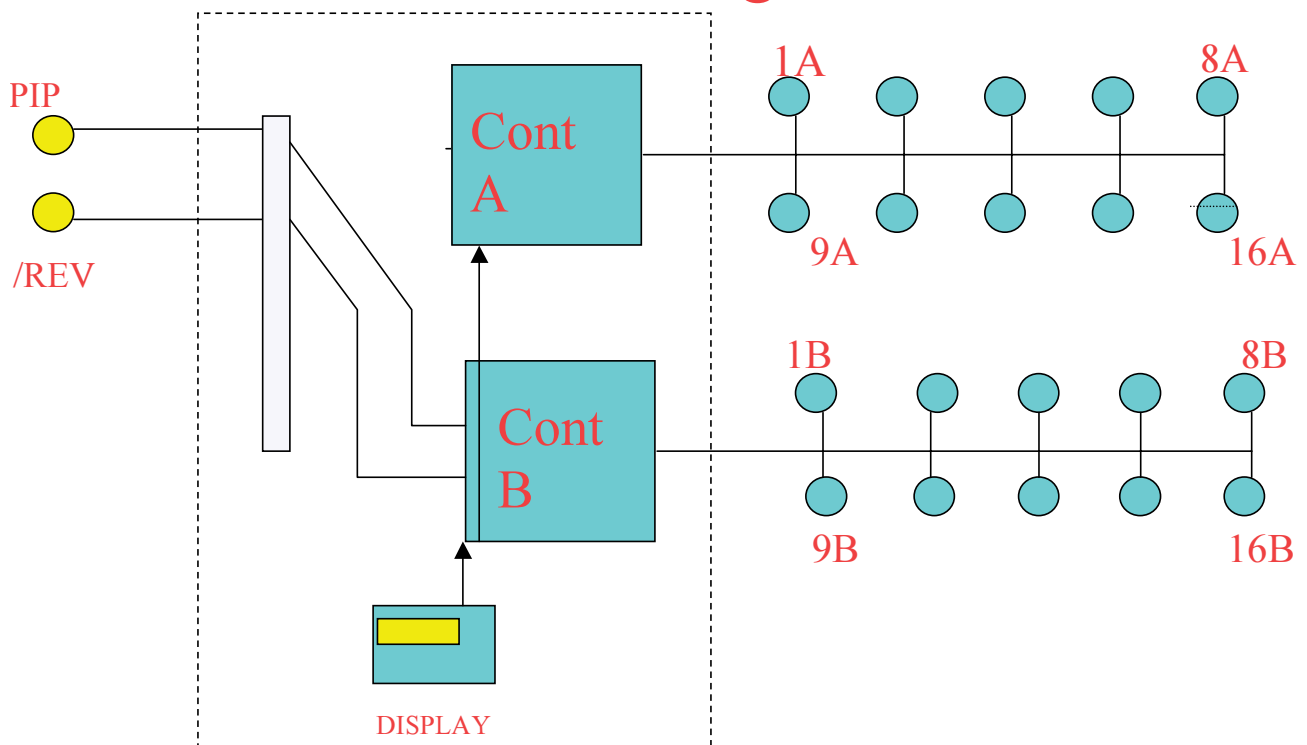

## 2. Installation

This sections discusses the field wiring requirements.

### 2.1 Input connections

The din rail terminal strip position functions are in the same order as the individual board terminals. There are some subtle differences to be aware of and are defined below. The three terminal strips are “FTB (Field Terminal Blocks)-1A,B,C”

The first 12 positions, FTB-1A.

**Terminals 1,2:** 24 VDC Power Supply input.

It is recommended that both the positive (position #1) and negative (pos. #2) are separately fused. Each fuse can be 3-5 amps.

**Power Supply Needed:** 18-30 VDC @ 4 amps cont.

**Terminal 3:** Earth ground .

This is an optional input that can be used to land the external earth ground wire. This wire is normally secured to the grounding stud located on the enclosure door.

**Terminals 4,5,6:** Ignition On Relay contacts.

These contacts are internally wired so that the normally open contacts are in series. This should be use to turn on a fuel valve so that both controllers A & B have to be firing before fuel is applied.

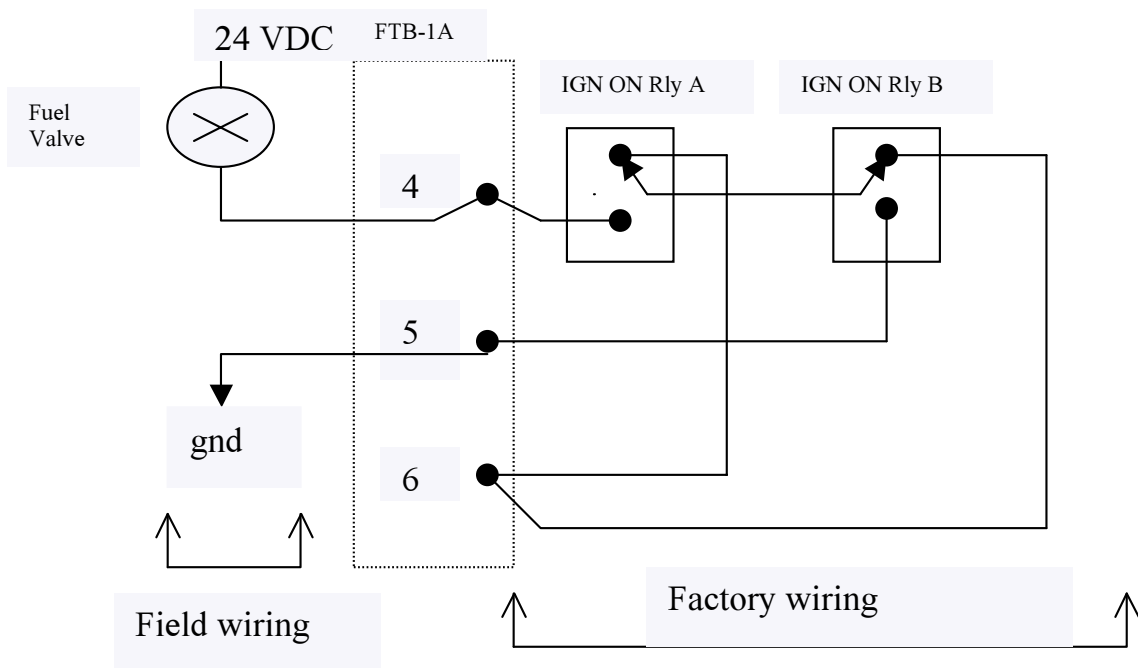

**Terminals 7,8,9 : Alarm Relay Contacts.**

*These contacts are wired in parallel as shown. Either controller will provide a closure when an alarm is encountered. The alarms are non-critical which indicates a condition that is out of range but not so far that it should cause the unit to shutdown. For example, the 24 volt supply may droop to below 20 volts during start-up, this would cause an alarm but not a shutdown.*

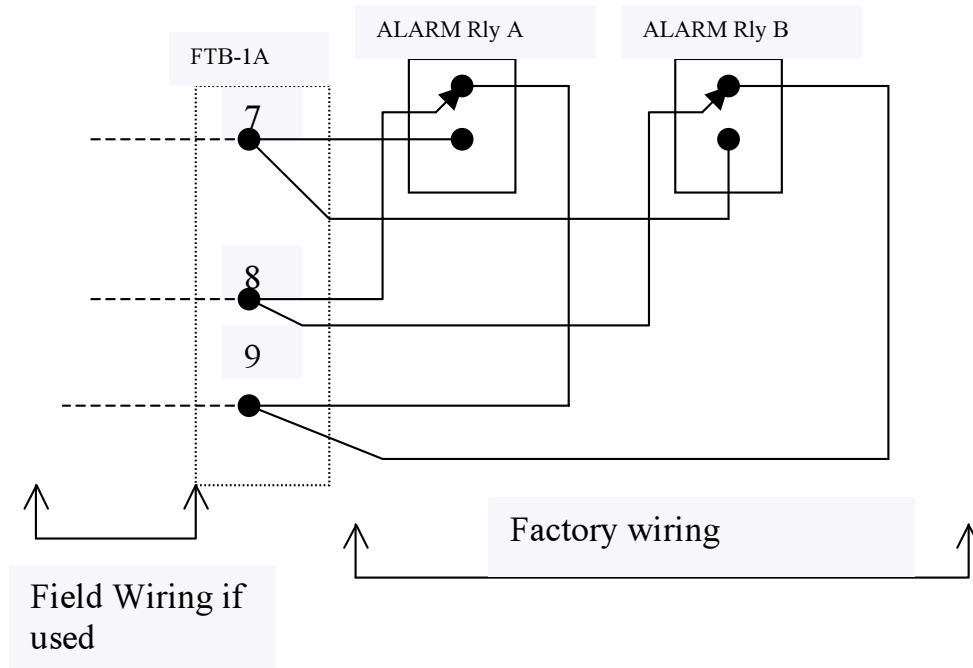

**Terminals 10,11,12 : Shutdown Relay contacts.**

*These contacts are wired in parallel so that if either controller shuts down it will signal the externally connected equipment a shutdown has occurred.*

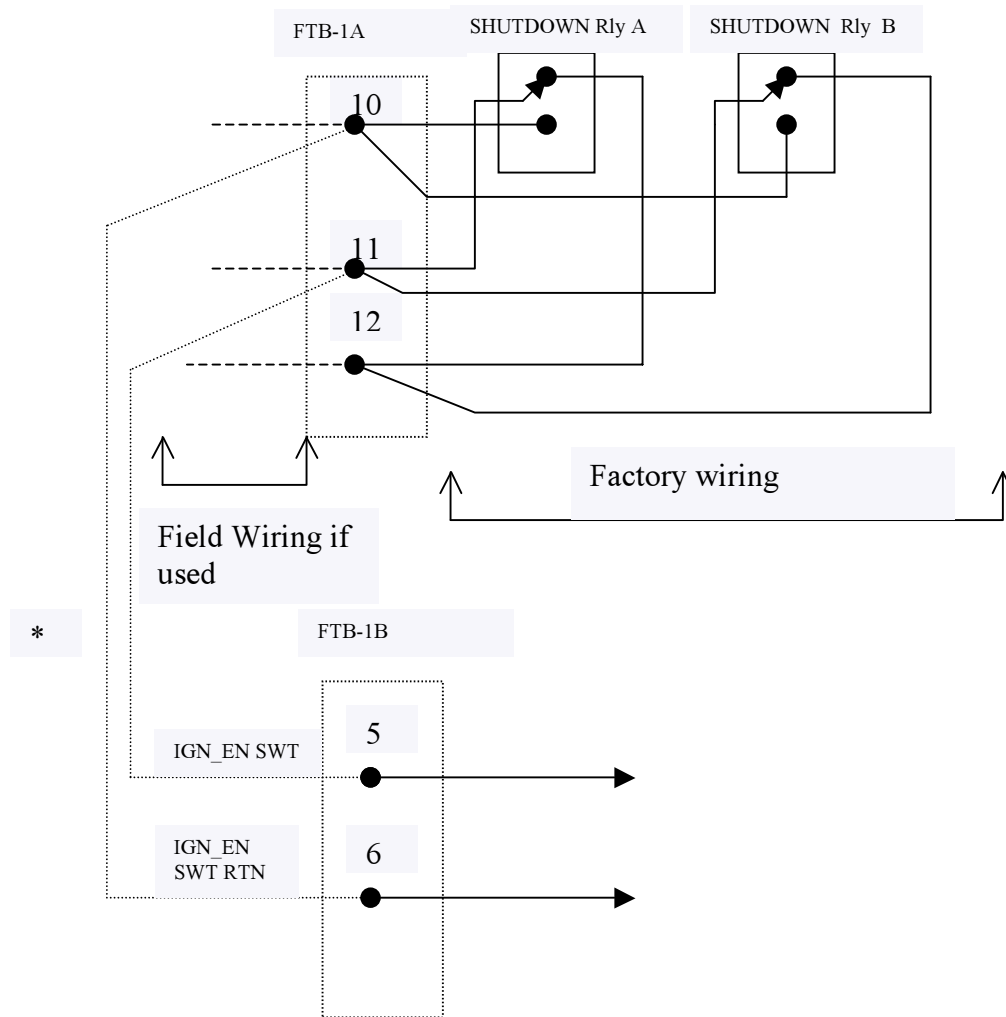

*\*: Wiring the shutdown contacts over to the Ignition Enable input is an optional arrangement that causes both controllers to shutdown upon a shutdown originating from within either controller. Care should be taken to determine if this is the best method. If this method is used then only one primary harness "U" lead needs to be used to "kill" ignition. When the "U" lead is grounded it will generate a shutdown activation for the respective controller which in turn energizes the shutdown relay and subsequently disables both controllers. When the "U" lead ground is lifted the shutdown relay will de-energize allowing the unit to start again.*

## FTB-1B

**Terminal #1:** Shield, this position can be used to land cable drain wires or shields.

**Terminals 2,3,4 :** These three positions are used to connect to a Hall-Effect sensor that detects the camshaft position. MPI recommends that only the MPI sensor p/n 200201-A and the 200211 are used. Other mfr sensors can vary in electrical requirements and in their operation, which cannot be guaranteed by MPI.

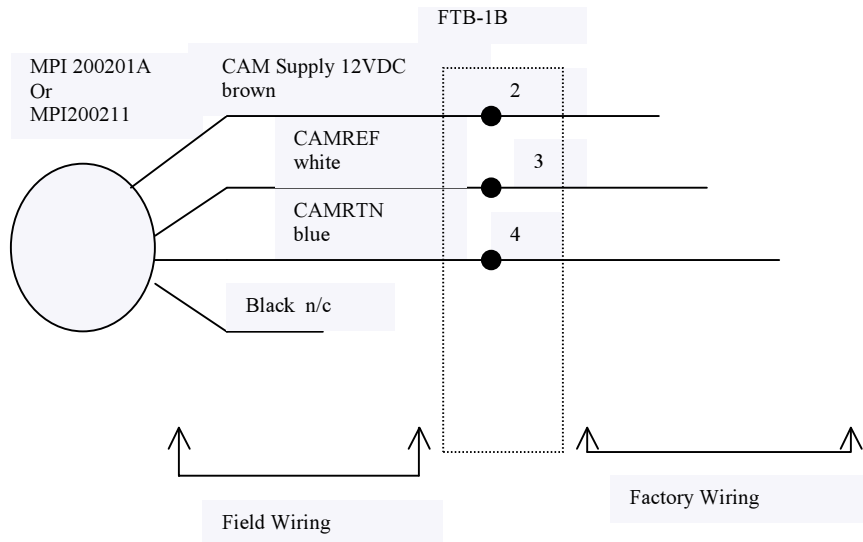

**Terminals 5,6:** Ignition Enable input. A dry contact with no voltage source connects to this input. A closure disables ignition. Also shown is the optional wiring that can be added in parallel to an external switch. The optional wires are connected to the shutdown relay NO,COM contacts on FTB-1A.

If either controller generates a shutdown the shutdown relay contacts will close and disable both controllers. Once the controllers go into the STANDBY mode, i.e RPM = 0, the shutdown relay is turned off allowing the unit to re-start.

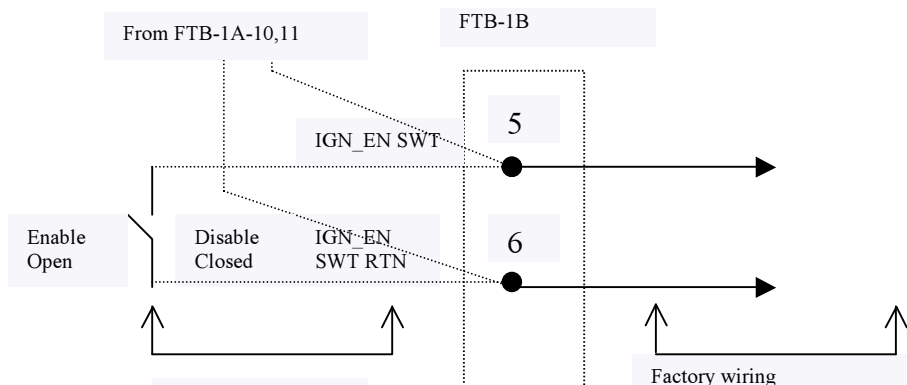

**Terminals 7,8 : A/B Select.**

If this input is left open then schedule A remains in effect. A dry contact closure across this terminal pair signals the firmware to use timing schedule B.

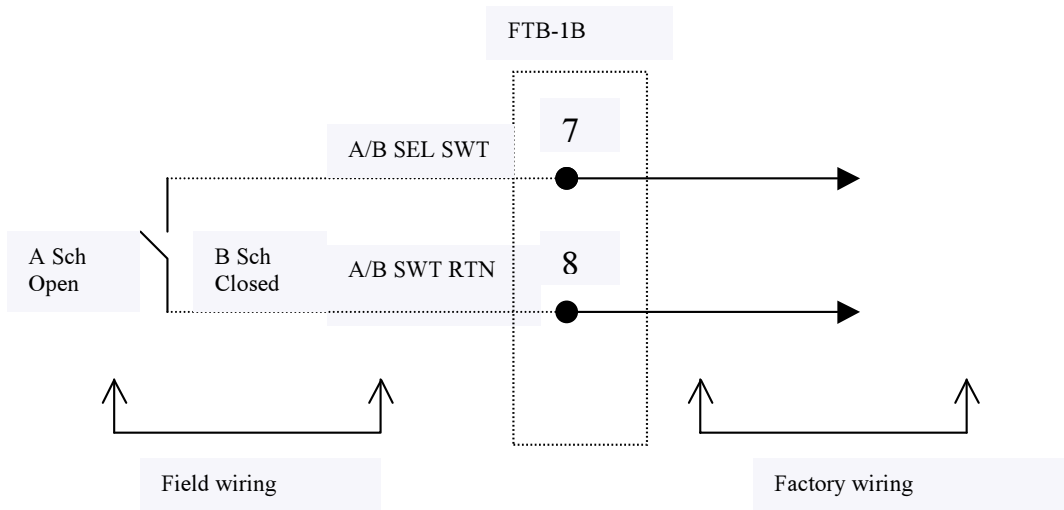

**Terminals 9,10 : Alarm\_Ack, rtn**

This contact, when closed will clear any alarms in the alarm history list for both controller A & B. The use of this input is optional, the alarms may also be cleared by pressing F2 on the alarm page.

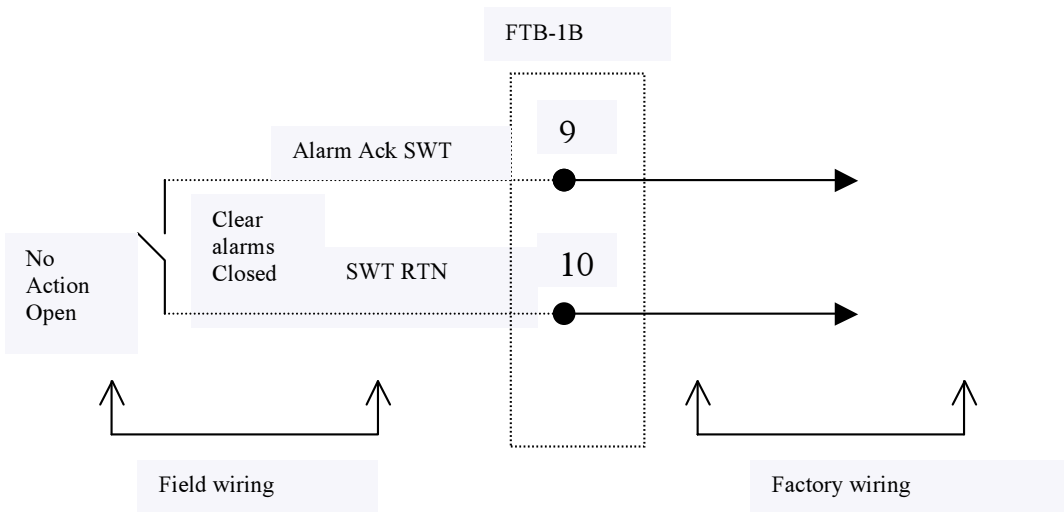

**Terminals 11&12: Spares.** These terminal positions are left blank.

## FTB-1C

**Terminals 1-6:** These terminals are for connecting the crankshaft sensors. Two schemes are shown, one using the MPI dual Hall-Effect, and one using mag pick-ups.

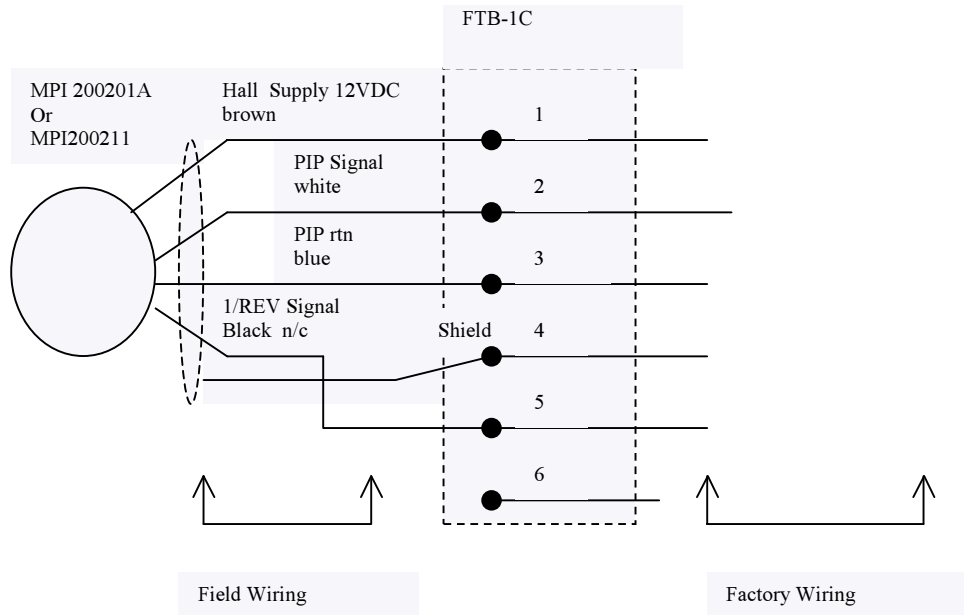

**OR**

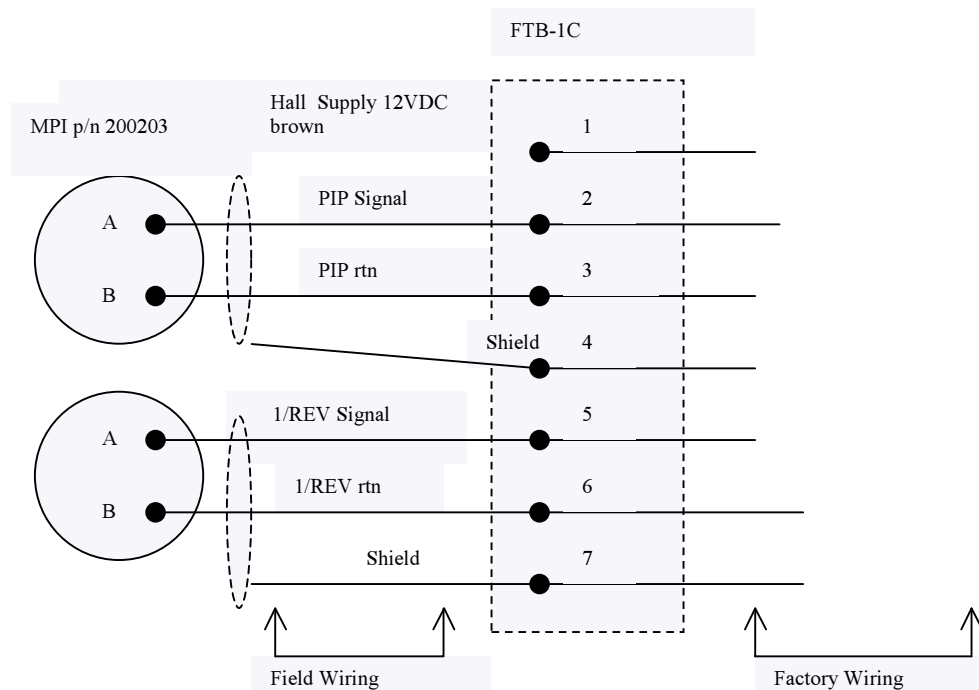

**Terminals 8,9,10,11,12: 4/20 mA input for schedule A & B**

*These inputs are ground referenced therefore they cannot be used in a floating ground mode. These inputs may also be used with a transducer with a voltage output signal that ranges from 0-5 volts.*

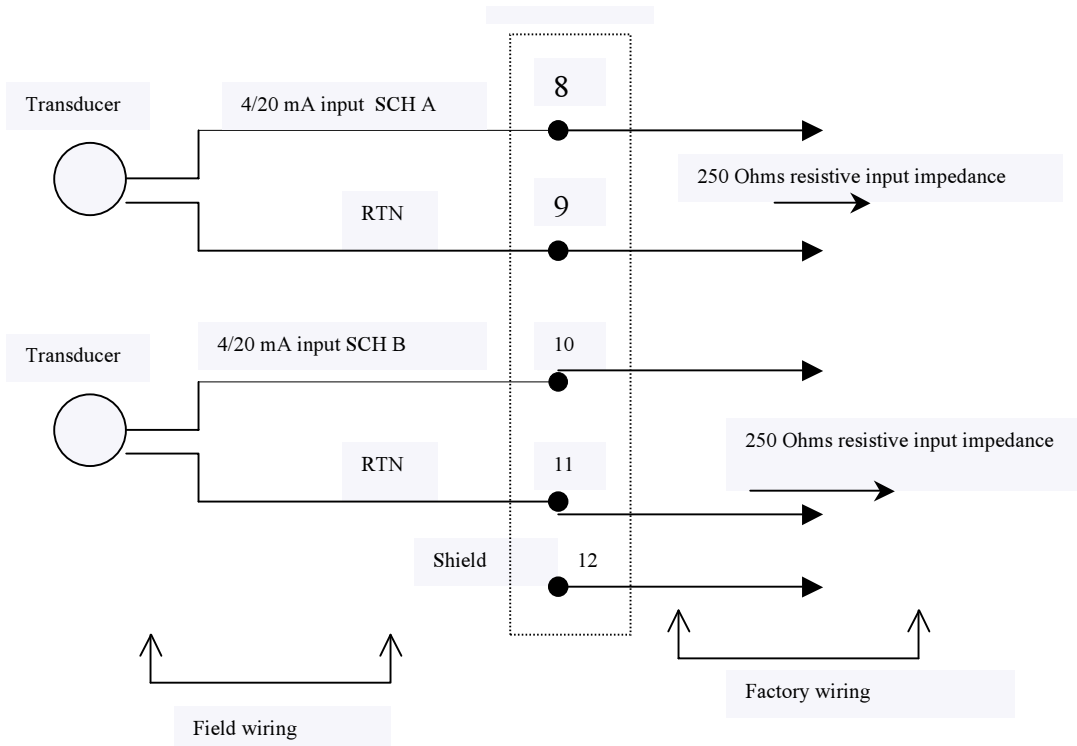

**Note:** *One or two transducers can be monitored by the MPI-32 and used just to show the transducer's output without affecting timing.*

## 2.2 Output Connections

*This section discusses the wiring requirements for the output harnesses.*

*Each controller has its own output primary harness connector. Each set of coils need to be wired independently. One exception is the connection of the “U” lead. If a U lead is shorted to ground it will kill that particular controller. The other controller would continue to run unless the shutdown relay contacts are wired as shown in the Input Connections section where the N.O. contacts of both controllers are jumpered in parallel across the Ignition Enable input. In this case shorting either U lead to ground will cause its associated controller to activate its shutdown relay subsequently shorting the Ignition Enable input which is common for both controllers and this would disable (turn off) both controllers.*

*If it is desirable not to jumper the shutdown relay contacts to the Ignition Enable input, then the U leads from each harness can be jumpered together and grounded as a single lead to kill both controllers from an external device such as an annunciator. There is no problem tying them together and powering any standard CD powered device. With both U leads tied together more power is available to operate more devices.*

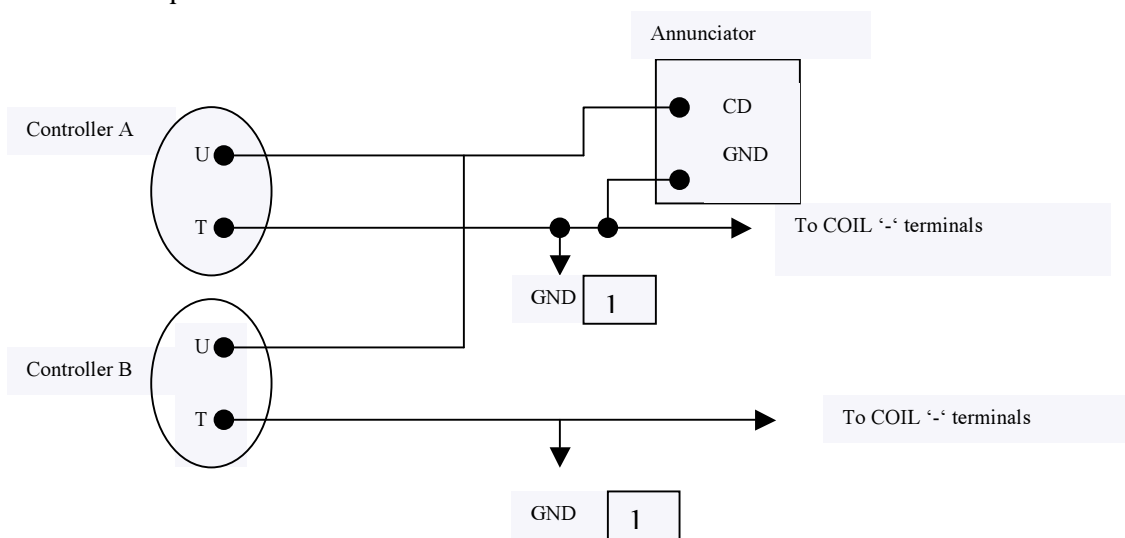

- Notes:**
1. Both “T” leads need to be grounded
  2. Each harness should have one sense lead terminator on a coil in that respective harness.

## 3.0 PROGRAMMING

*Programming the MPI-32 for a specific engine application can be performed in two ways.*

1. *Using the MPI display/keypad device.*
2. *Using the MPI-Prog software*

### 3.1 Programming through the display/keypad unit.

*The MPI-32 display contains roughly twice the number of pages as the MPI-16. Each controller in the MPI-32 has its own set of dedicated pages including “Operator Pages”, “Diagnostic Pages” and “Programming Pages”.*

*Each set has an “A” or “B” in the upper right hand corner of each page to indicate which the controller is being observed. The user need only press F1 until the page showing “Select Controller” appears at the top, then follow the instructions to get to the controller of choice.*

*Controller A is the primary. When the engine is running the user would normally select the A unit to see basic operating parameters such as RPM etc. There are five parameters that can only be changed on controller A and they are automatically updated in controller B so that each controller uses the same value for these parameters. They are:*

- Timing Adj*
- Auto Delay Value*
- Auto/Man Mode select*
- Tank Voltage Request*
- I/REV position*

*It makes sense that both controllers operate with these particular parameters set to the same value.*

*The basic timing curves do not have to match. The user can program the B controller to fire its’ set of coils at a different timing angle than the A controller. Some engines require a staggered timing angle between the two plugs. The MPI-32 can do this.*

*The most straightforward way to program the unit is to select controller A and program all of the parameters for it in standard fashion. After all the parameters are set, the user should go back to the “Program Page”. On this page there is an option “F4: Copy A to B”. Pressing this function key starts a process whereby the display/keypad will read a block of parameters from A and then write them into controller B. This process repeats until all of the parameters are copied over. Each block transfer has a job number assigned to it. The maximum number of word transfers per job is 30 so it requires 5 jobs to move all of the necessary data. The first job is #6, the last one #10. (Jobs 1-5 are the automatic transfers of the real time data , Timing Adj, Tank VoltsReq etc.) Due to the large number of parameters, it may take from 5-15 seconds to complete the copying process. The copying process can be observed by watching the following parameters:*

#### ***MBXSTAT, MBXCMD, MBXJB and MBXPI***

*These parameters comprise the “mailbox” structure for transferring data from controller A to B.*

***MBXSTAT:*** *this parameter provides the handshaking between controller A and the panel. The panel monitors this parameter to check for a request to execute whatever command has been placed in the MBXCMD register. In order to stay synchronized the panel only responds to changes made in the MBXSTAT register by the controller.*

*When the user presses F4, a panel macro command writes the first job number into the MBXJB parameter. The controller detects this non-zero number and writes a “1” to MBXSTAT. The panel sees this value as a signal to read the command register and execute it.*

**MBXCMD:** This parameter contains the actual command interpreted by the panel when MBXSTAT has a "1" written to it. Only one command is used (#49) and that is the controller to controller transfer command.

**MBXJB:** This parameter performs two functions. 1) It contains the job # for each transfer of a data block. Each job # has the specific data that is to be transferred from A to B. 2) It is used to initiate the process. When the user presses F4 the job# gets changed from "0" to "10". The controller A firmware responds to this by writing a "1" into MBXSTAT that alerts the panel to begin processing the jobs.

**MBXPI:** This parameter is used to specify the last job # to run. In the panel the first 5 jobs are executed on a time base to keep the real time parameters ( Timing Adj, Tank VoltReq etc.) updated. The first block transfer that is part of the copying process is job #6. As each job completes the controller increments the job # until the job # exceeds this parameter (10).

After a power up is performed the parameters will have the following values:

MBXSTAT (status word)	: 5 – panel has been reset
MBXCMD (command word)	: 0 – no commands set
MBXJB ( job #)	: 0 – no jobs specified
MBXPI ( starting job # )	: 0 – no jobs specified

When F4 is pressed the parameters take on the following values:

MBXSTAT	: 1 – request transfer of data
MBXCMD	: 49 – start controller to controller transfer
MBXJB	: 7-11 – shows jobs 7 thru 11 while executing
MBXPI	: 10 – this is the last job number

When the entire job is finished the values should show:

MBXSTAT	: 4 – ready for another transfer
MBXCMD	: 49 – ready for next controller to controller xfer
MBXJB	: 0 – no jobs to do
MBXPI	: 10 – last job number

When the copying process is complete the user must press F3 to save (program) all of the data edited for controller A and all of the data copied into B. Afterwards the user can go into the B program pages and make changes required that would be unique to B.

### 3.2 Using the MPIProg Software

The MPI-32 can be programmed with the new the MPI Prog software and a PC. Provisions are made in this software to select the MPI-32, which will make the software "Download" into both A & B controllers with a single download request. Refer to the manual for this program for further details on its use.

## **4.0 Start-up Procedures**

*The start-up procedures are similar to that of an MPI-16.*

- 1. Verify the programmed data are correct on both controllers A & B.*
- 2. Verify KV measurement system is functioning for each controller.  
Each controller can be operated in its diagnostic mode independently.*
- 3. Verify the firing order for each harness using the diagnostic mode and generate a fault condition for each coil. An open-pri or open secondary are easy to do. Verify the appropriate error message appears next to the correct pin designator.*
- 4. Perform a dry-run (no fuel) start and verify the IGN parameter on the first page come "ON" for both controllers. The IGN ON relay can also be monitored to verify ignition has come on. This relay is labeled K1 and is adjacent to the main input power fuse, FH1. There is a small LED (D74) that illuminates when the relay come on.*
- 5. If step 4 is complete, start the engine with fuel enabled. While its idling verify the actual timing for cyl #1 using a timing light agrees with the displayed timing on the MPI. If there is any minor disparity it is probably due to the I/REV signal not coming in at exactly TDC (or the expected angle). Use the parameter "I/REV Position" to fine tune the timing angle shown by the light until it agrees with the display. If there is a large disparity, more investigation as to the cause should be pursued.*
- 6. Verify the KV parameters with the engine at normal load. If new spark plugs were installed the message "<5KV" may show on many of the cylinders even at full load. As the plug wears the KV demand will rise and voltages should be observed.*
- 7. If applicable, verify turbo-charger rpm. A difference in timing will affect the turbo's speed.*
- 8. Verify exhaust temperatures for normal values. These values are very sensitive to ignition timing.*
- 9. Verify speed stability is good and that the engine has no more than normal vibration.*
- 10. Verify fuel consumption is within the normal range. This value is also very sensitive to ignition timing.*

## 5.0 Troubleshooting

*The MPI system has been designed to provide users with messages and parametric values to assist diagnosing problems internal and external. The more familiar a user becomes with these capabilities the faster he will resolve any problems.*

### 5.1 Differences between Shutdowns and Alarms

*A **Shutdown** is that single event that occurred to signal the MPI firmware to cease ignition and post the singular message on the shutdown page. This message will stay posted until a re-start is made. The user does NOT need to cleared or acknowledged. This section will discuss each shutdown message and probable cause. In the event of a shutdown there is a specific relay (K3) that can be used by other equipment as an indication the MPI issued a shutdown.*

*An **Alarm** is an event that includes any shutdown event and many events that are of a less serious nature that are posted as a courtesy to the user. Alarms can be cleared anytime or ignored, as many alarm events are part of the normal operation. For example, many electric starters pull the main voltage down below the user programmed alarm level during cranking. A message will appear "LOW BATTERY" but it is not a cause for shutdown or concern as long as the voltage returns to normal levels after the started disengages. If however this alarm appears "out of the blue" then some further investigation is warranted. As another example if the PIP count was not perfect and less than the tolerance specified in the program page for a shutdown, an alarm will show a message "PIP Count". If this message has shown up after many months of normal run time it could indicate that the sensor is having problems, maybe getting a lot of contamination on the face and in this case the user would note this and check the sensor the next time the engine is down.*

*The user needs to become familiar with the system shutdowns and alarms to make informed decisions.*

### 5.2 Shutdowns, their causes and what to do.

*The following messages can appear on the shutdown line.*

#### 1. " PIP Shutdown"

*This shutdown is generated whenever the PIP count, taken at the occurrence of a 1/REV signal, is different than the programmed count by an amount equal to or greater than the PIP Tol (tolerance) parameter. It does not necessarily mean that the problem is with the PIP sensor. The PIP count depends on both the PIP and 1/REV sensor. For example, if the number of PIPs programmed was 183 and a count of 100 was measured, this shutdown would activate. The most likely cause is an occurrence of an extra 1/REV at the 100th gear tooth position. It could also mean that the PIP sensor did not pick up some gear teeth because of some unexpected flywheel run-out problem. If the PIP Shutdown occurs more than once and the errant count is consistent then the extra 1/REV is most likely. If the count at shutdown is inconsistent it is more likely caused by the PIP sensor.*

*On the second page there are 5 parameters at the bottom that are the last 5 periods of the 1/REV signal. They're in hexadecimal notation and are actually the number of internal clock ticks. They not easily converted to any meaningful numbers. However, engineers at the factory can take these numbers and determine if the last period measurement was consistent with the previous 4. If it is not then the mostly likely cause of the shutdown would be an errant 1/REV pulse and not a problem with the PIP sensor.*

#### What to do.

*If mag pick-ups are installed the user/mechanic should pull out the wire pairs and put an ohmmeter on them for both the PIP and 1/REV. The resistance should be 400-500 ohms. If the reading looks good, then pull out the pick-ups and check for contamination on the face. If an errant 1/REV pulse is suspected them the flywheel should be inspected around the 100th tooth (refer to example above) for any protrusions or stamped lettering etc. Also check for other holes in the proximity.*

*If an MPI hall-effect is installed it can be checked statically by putting a voltmeter on each input (PIP & 1/REV) and then bring a test magnet to the face and observe the voltage drop to less than 1.5V, then back up to supply voltage when the magnet is moved away from the face. The hall-effect elements are polarity sensitive. If the test magnet polarity is not known the user should check both sensor outputs, one should react. The test magnet should have a strength of 300-400 Gauss minimum.*

## **2. “Per Rev Shutdown”**

*This shutdown is caused if the running PIP count exceeds the programmed value by 10 counts. This could also be caused, but much less likely by the PIP sensor generating too many pulses. This can happen if the ring gear makes contact with the sensor. The most likely cause is the 1/REV sensor has become contaminated or a wire is broken in the 1/REV circuit.*

*Another potential cause is that the signal width becomes too small to get recognized. This can happen if a small target is used (hole or protrusion) and the speed becomes high enough that the signal width drops below 100 microseconds.*

*This can also be caused by the gap being too wide making the pulse width narrow.*

*What to do.*

*If the width of the pulse is suspected to be the problem the course of action is to try to make the pulse width wider. If a hole were in use then making it larger would help. Sometimes the hole does not pass directly under the sensor, which would make pulse narrower. The sensor should be moved or the hole enlarged to correct this.*

## **3. “CAMREF Shutdown”**

*This message signifies the cause of shutdown was due to a loss of the camref signal. It can also mean that the camref is out of alignment with the 1/REV. The tolerance is user programmed.*

*What to do.*

*The state of the camref input is displayed on page 2. If the engine is barred over the CAMREF parameter should change from a “HIGH” to a “LOW” when the target magnet comes under the sensor head. During the period when the signal is “LOW” the 1/REV hole or protrusion should pass under the 1/REV sensor.*

*If the parameter never goes to the low state the gap should be checked*

*( should be between  $\pm 1$  turn out). Then sensor can be tested with a separate test magnet. The normal sensor output is the North Pole channel so the test magnet must be used so that it's north pole faces the sensor.*

*If the parameter does go low with the presence of the target magnet it would indicate a mis-alignment issue.*

*As with any sensor problem all connections should be visually checked for broken or frayed wiring.*

## **4. “Overspeed Shutdown”**

*As implied this shutdown was caused by the engine rpm exceeding the programmed value for overspeed. There is also an additional requirement for this shutdown to occur and that is the length of time the engine rpm was exceeding the limit. The persist time, i.e. that duration for exceeding the overspeed limit is user programmable. For most engines the governors cannot tightly control the overshoot of rpm with respect to the governors setpoint. This is especially true during light loads or for coming out of cranking and ramping up to idle speed. The persist time allows the engine to go above the overspeed limit for a brief period without causing a shutdown. The default for the persist time is 0.5 seconds, this can be adjusted to compensate for the particular governor response.*

What to do.

*The cause of the overspeed may be due to other systems or factors beside the MPI that need to be directly addresses. The load may have dropped suddenly causing the speed to spike upwards etc. If the engine operates near the overspeed threshold, the persist time may need to be increased to prevent short transient excursion above the limit from causing a shutdown.*

#### 5. “RESET > Crnk Shutdown”

*This shutdown is generated if the 24 volt supply is turn off and then back on while the MPI was in the normal run mode. When power is applied the system goes through a power on reset and if the first speed measurement after reset is found to be higher than the crank-run threshold (normally 400 rpm) then a shutdown is issued to prevent igniting fuel that could be present throughout the intake and exhaust system for the short time the ignition was turned off.*

What to do.

*The cause of this shutdown could be with the 24 VDC supply system. The display shows the average voltage on the input but it does not show any short duration droop spikes that may be the shutdown. In this case only a peak and hold meter will work or a scope.*

*Another possible cause is a heavy noise spike from a device connected to the 24vdc supply in parallel with the MPI. A large solenoid valve can generate high voltage transient spikes that can cause problems. All inductive loads should be diode snubbed to clamp any inductive spikes from occurring.*

#### 6. “Ign En Input Disabled”

*This shutdown is caused by either grounding the “U” lead or the discrete input, Ignition Enable, was shorted by an external device such as an annunciator etc.*

*The system wil lbe ready to start once the “U” lead is un grounded or the IGN En input is no longer shorted by an external device.*

#### 7. “ Comp/Exh Detect Flt”

*This message indicates the system failed to start because it could not determine the compression stroke using the “camless” method. This message will never appear as a shutdown cause during normal run time.*

*This shutdown has a programmable threshold for a parameter that is referred to as the “cam test count”. The user can refer to the main MPI manual for complete details on how that process works. An abbreviated discussion of this is provided here.*

*The compression detection relies on the phenomenon created in the cylinder during the compression stroke. That is that when the air in the cylinder undergoes compression. The pressure creates a higher dielectric in the plug gap which requires a higher voltage to jump the gap.*

*When the engine starts to crank the MPI fires cylinder #2 in the F.O. and the rest of them in the correct F.O. for that one revolution. The KV readings of each firing are taken and saved. The same cylinders are fired again in the second revolution. For one rev the cylinders will be on the compression stroke and for the other on the exhaust stroke. The voltage to jump the gap on the exhaust stroke will be lower that those firing on the compression stroke due to the near atmospheric pressure on the exhaust stroke. The MPI evaluates these KV readings and can determine by comparing the relative KV required to jump the gap, which stroke was exhaust and which one was the compression.*

*These readings are collected for four revolutions so there are two revolutions of compression readings and two revs for exhaust.*

*For the MPI-32 both controllers must individually determine compression distinction. If the readings to not show a significant difference between the test firings the system will display this error message and stop.*

*What to do.*

*If this error message is displayed the first thing to look at is the actual “test score” that was achieved on the last start up attempt. It may only require an adjustment to the score threshold to allow it to run. For example, if the score achieved was 6 and the threshold is set for 9 it would be a good idea to drop the threshold to 6 and attempt a re-start.*

*This low score situation is most prevalent right after new spark plugs are installed since that is when the demand is lowest due to the narrow starting gap. As the plug wears the scores will normally improve.*

*If the score was “0”, then the KV measurement needs to be checked out and made to work properly.*

#### **7.0 “Bad Flash Checksum”**

*This message will appear if any of the programmed data that resides in flash memory changes without any operator intervention. At power up the system calculates a checksum on the engine data and compares it against the checksum that was calculated after the user had last programmed and save data.*

*What to do.*

*If this message appears, the general conditions should be noted and the factory contacted. Things such as an occurrence of an electrical storm, any new equipment installed on the engine etc. may help determine the exact cause of this error message.*

## **6.0 General Specifications**

*Power requirements:*

*Controllers : 12-32 Volts 3.0 amps max (for both controllers)*

*Display: 18-30 VDC, 250mA*

*Environmental:*

*CSA for Class I, Div 2 Group B,C,D (Pending)*

*Operating Temp: -20, +70 C*

*Inputs:*

*Crank Signals:*

*PIP: (Position Input Pulse) Mag pick-up or hall-effect interface*

*Minimum amplitude: 2.5 volts*

*Number of teeth, holes or magnets: 30 min- 360 max*

*1/REV (Once per Revolution) Mag pick-up or hall-effect interface*

*Minimum Amplitude 2.5 volts*

*Location: TDC #1 +,- 15 degrees*

*Camshaft Signal (if required)*

*CAMREF: (Camshaft reference) Hall effect, internally pulled up to 12v*

*Outputs:*

*Coil drivers: High-side firing,*

*Open circuit or shorted output will not cause any damage.*

*Mechanical:*

*Length: 12”*

*Width: 12”*

*Height: 12”*

*Weight: 27 lbs*